



COILCLEAN R/T

SANUVOX GERMICIDAL ROOFTOP UV

The Sanuvox CoilClean RT is an Ultraviolet Object Purifier specifically designed for exterior rooftop HVAC units. The CoilClean RT employs Patented Sanuvox Technology to keep the a/c coil free from biological contaminants including mold and fungus. The UV Purifier uses a weatherproof NEMA 4X Housing, a High Intensity 19 mm. Quartz Germicidal Lamp and an Aluminum Parabolic Reflector to direct and intensify the UV Energy that would otherwise be lost, ensuring a coil free from microbial growth. The CoilClean RT is available in two sizes, the RT24 which has a 24" Lamp and Parabolic Reflector and the RT30 which has a 30" lamp and Parabolic Reflector.



DESTROYS MOLD & OTHER BIO-CONTAMINANTS ON COIL



QUICK & EASY INSTALLATION LAMP CHANGES IN SECONDS



NEMA 4X BOX & HI-INTENSITY UV-C LAMP

FEATURES

- Destroys mold & fungus which is on, or may grow on the coil
- Eliminates biological odors that contributes to Dirty Sock Syndrome
- Improves energy savings, reduces maintenance & prolongs coil life
- Two year 3rd Party University Double Blind Study on the CoilClean series shows drastic reduction in mold & Sick Building Syndrome symptoms
- Patent Pending Parabolic Reflector intensifies and directs UV Energy
- Higher UV Intensity & Reliability than other UV Lamps/Emitters
- Parabolic Reflector shields plastics & rubber from UV exposure
- Efficiently operates between 35 and 170° F
- Available in 24" & 30" models depending on coil size
- Longer warranty than competing products
- Sanuvox Design & Quality
- CSA/NRTL Certified

"ELIMINATE DIRTY SOCK SYNDROME"

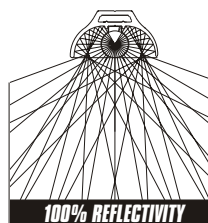

HI-INTENSITY 180 µW/cm² of UV GERMICIDAL ENERGY @ 1 METER

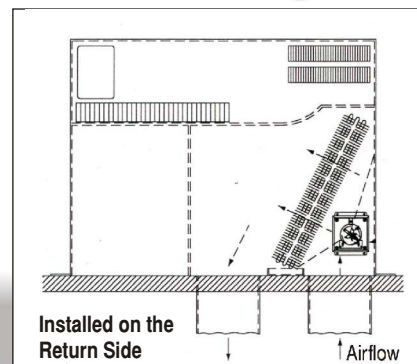

VERSATILE INSTALLATION

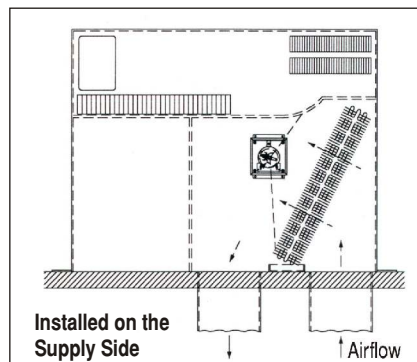

TECHNICAL SPECIFICATIONS

Housing:	Weatherproof NEMA 4X Housing
Weight:	12 lbs (5.5 Kg)
Power Requirements:	208/230V AC (120V AC on special order)
Starting:	Hardwired to HVAC air handler unit
Ballast:	Electronic Rapid Start Ballast. Ballast is potted to protect from corrosion
UV Lamp:	High Intensity 19mm. Germicidal Pure Fused Quartz
UV Lamp Features:	Getter absorbs inner lamp contaminants, low mercury levels
UV Lamp Length:	Coilclean RT 24 is 24 inches. Coilclean RT 30 is 30 inches in length
UV Intensity in µw/cm ² (microwatts):	180 microwatts per cm ² at 1 meter
Parabolic Aluminum Reflector:	Coilclean RT 24 is 26 inches. Coilclean RT 30 is 32 inches in length
Certifications:	NRTL/C, CSA.
Warranty:	Unit: 5 years. UV Lamp: 12 000 Operating Hours.



COILCLEAN R/T

SANUVOX GERMICIDAL ROOFTOP UV

Models: COILCLEAN RT24G; COILCLEAN RT30G

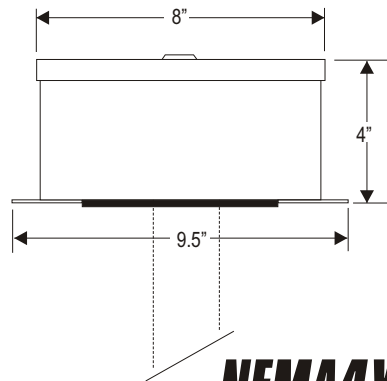
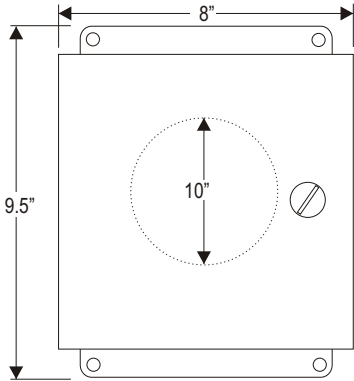

NEMA4X

The ideal location for the CoilClean RT series is on the return side of the coil, near the bottom of the coil, facing up into the coil, about 6 to 10 in. away from the coil. In many cases this is not possible due to the filters being located within two inches of the coil. If the filters can not be relocated, or if there is some other obstruction in this area, then the Coil-Clean RT unit will have to be mounted on the supply side of the coil near the top of the evaporator coil, a minimum of 6 to 10 in. away from the coil, with the UV light directed down-ward onto the coil. If the CoilClean unit is installed on the supply side of the coil, then the reflector/shield will have to be taken out and cleaned every

few months, as particles will accumulate on the lamp and reduce the intensity of the UV light. The CoilClean RT units can be mounted in a horizontal or vertical position. More than one unit can be used if needed. Make sure site can be supplied with the necessary power re-quirements. Ensure that there is adequate clearance for service.

Installation

Cut out a 4" diameter hole or a 4" x 4" square hole
Mark the [4] mounting holes and drill a 5/32-diameter hole through the panel.

Secure the NEMA 4X. box using the [4] screws supplied with the unit.

The lamp and reflector/shield assembly may easily be rotated via the attached handle to orient the radiation accordingly. The reflector/shield can be rotated 360 degrees for positioning so that the UV rays will be directed onto the coil.

All of the area behind the reflector/shield is completely safe from UV rays. Insure that any plastic or rubber that is in the direct view of the UV rays is covered with aluminum foil or aluminum tape.

The RT 24 and RT 30 CoilClean models are designed to operate on 208-240 V. AC. The CoilClean RT units should be wired to the disconnect switch of the air handler so that they will only be powered when the air handler is powered.

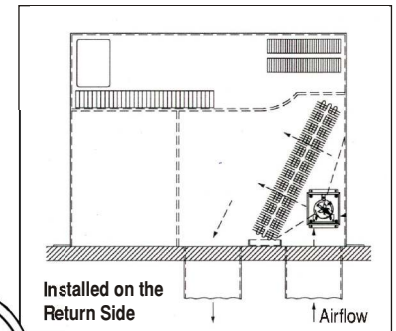
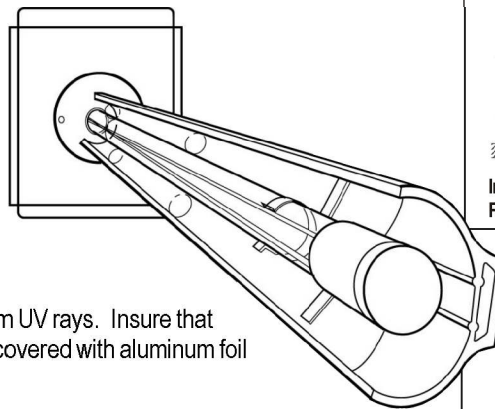

VERSATILE INSTALLATION

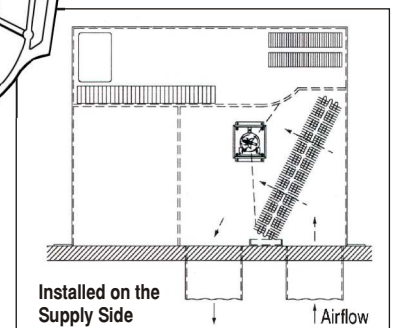

CoilClean RT Model	Replacement Lamp Number	UV Lamp Length	Microwatts per/ cm ² at 1 meter
CoilClean RT24G	SAN-HI24	24"	155 microwatts per/ cm ² at 1 meter
CoilClean RT30G	SAN-HI30	30"	180 microwatts per/ cm ² at 1 meter

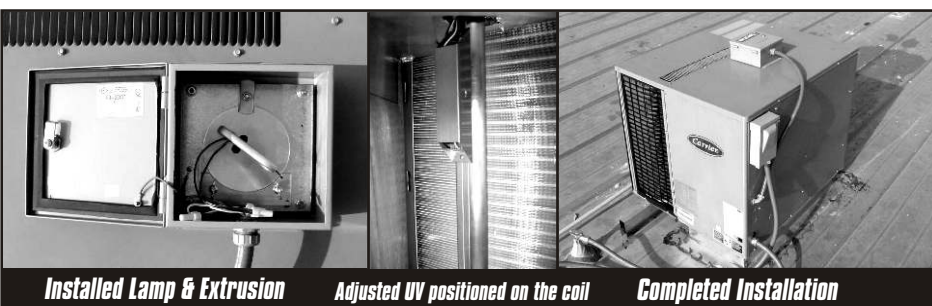

Warranty: Unit: 5 years. UV Lamp: 12 000 Operating Hours.

FORM# SUV-CCRT